

# Locomotive and carriage positioning, lifting and weighing system

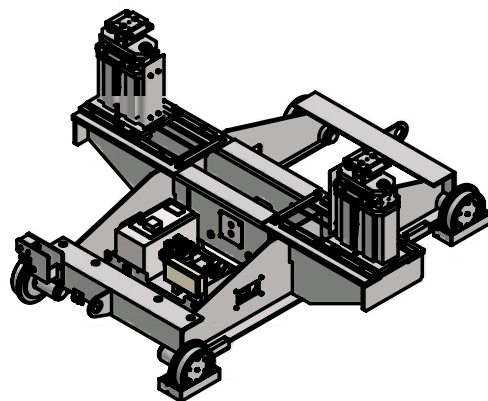
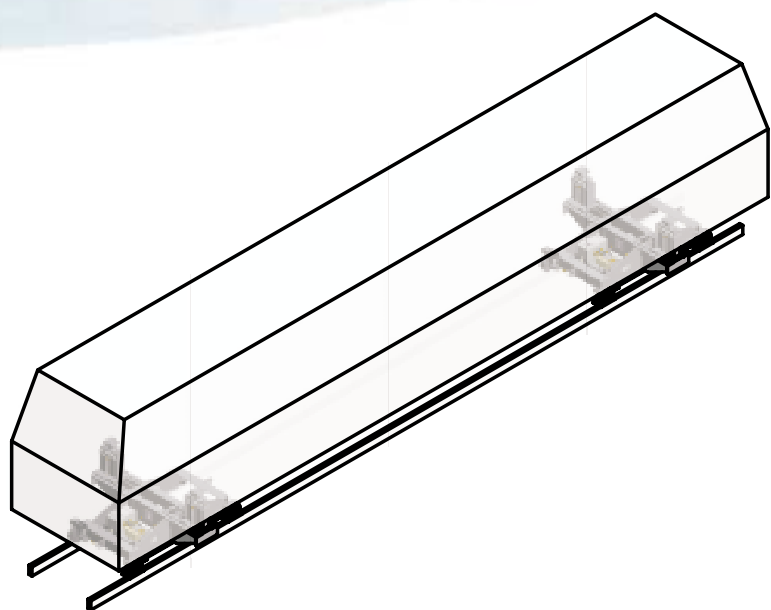

**ULBRICH**

[www.ulbrich-group.com](http://www.ulbrich-group.com)

## Operational Overview

During the production or servicing of locomotives and carriages it is often necessary to carry out assembly, service and repair work underneath.

Therefore, it is highly recommendable to be in the position to raise and lower the locomotive and carriages simultaneously, to specific heights to allow the optimal working clearance.

Due to the fact that the various construction, assembly and service stations are often situated in different locations throughout the plant; the need for the lifting system to be mobile is paramount. Upon completion of the lifting process, the operator can now utilise the optional load measurement and centre of gravity analysis module.



interchangeable  
contact surface

sensor to control  
load stability

mechanical stability  
from safety bolts



hydraulic wheel  
brakes

low noise high output  
power pack

safety bolts

## Technical Description

The lifting equipment consists of two mobile jacks. Integrated within the superstructure is a hydraulic power pack which drives the two hydraulic cylinders. The cylinders are situated in the highly robust and laterally adjustable lifting blocks.

The lifting blocks and the jack contact surfaces (lifting points) can be repositioned along the cross-beam via a spindle. This allows the flexibility to lift and control a number of different types of Locomotive and carriage.

Once the carriage has been lifted, the lifting blocks can be locked out using safety bolts which ensure that the height selected is safely maintained. The position of the safety bolts themselves can also be controlled by sensors.

An optional function to weigh and calculate the centre of gravity is available upon request. Here, the lifting blocks have been fitted out with "load cells", which can transfer the load input into a unit of weight. With the accompanying software these values can be evaluated in order to determine the centre of gravity.

## Technical Data:

Stroke force pro contact surface 125 kN  
(force can be increased upon request)

Stroke 500 mm (increased stroke upon request)  
Contact surface height at rest 1372 mm  
Contact surface height fully extended 1872 mm  
Contact surface laterally adjustable  
from 1500 - 2200 mm  
Power requirement 1,5 kW

Optional:

Weight analysis via x4 load cells (150 kN per cell)  
Weight measuring accuracy < 1,5 %

